



2400EVFX, 3400EVFX & 4400EVFX

Aerating Fountain

2400EVFX: 1/2HP, 50Hz, 220V, Single Phase

3400EVFX: 3/4HP, 50Hz, 220V, Single Phase

4400EVFX: 1HP, 50Hz, 220V, Single Phase



Operation

- ⇒ Submersed motor with top intake draws water into the fountain housing and pushes the water past the deflector disc and into the air.
- ⇒ Individual water droplets absorb oxygen from the atmosphere and return to the body of water transferring oxygen from the air and into the water.
- ⇒ Moving water mixes and agitates the water, spreading oxygenated water throughout the body of water.
- ⇒ Single propeller and deflector disc design allows for greater water flow with a lower likelihood of clogging.
- ⇒ Coated stainless steel bottom screen with 84 vertical bars with less than 2.5cm gaps shall catch large debris and assist in reducing the likelihood of clogging while allowing for maximum water flow into the unit.

Quick Facts

- ⇒ Operates on 208 - 240V, Single Phase Power
- ⇒ Complete Package includes Assembled Motor Unit, UV Resistant High Density Thermoplastic, EPS Filled Float, Two 15m Braided Nylon Mooring Lines, and Rubber 10m Power cord or 1m Stub cord with quick disconnect
- ⇒ Operates in 38cm (1/2HP), 45cm (3/4HP), or 49cm (1HP) of Water
- ⇒ CE Marked
- ⇒ Sacrificial Anode Installed for Corrosion Protection and use in Salt Water Applications
- ⇒ Series 300 Austenitic Stainless Steel Construction of Exposed Metal; Salt Water Compatible
- ⇒ 2 Year Warranty
- ⇒ UPS Shippable
- ⇒ Optional Lighting Package with 2 or 3 Machined Bronze Fixtures, Thermal Overload Protection, and 3 Internal Seal
- ⇒ Energy Efficient with Excellent m³/kW Rates
- ⇒ Industrial Strength Design
- ⇒ Top Intake for Shallow Water Operation
- ⇒ Bottom Screen with 84 Vertical Screening Bars with Less Than 2.5cm Gaps to Keep Debris Out and Allow for Maximum Water Flow Into the Unit

Single "V" Shape Pattern

2400EVFX: 1.2m H x 4.3m W
 3400EVFX: 1.7m H x 6.1m W
 4400EVFX: 2.4m H x 8m W

Features

Motor Unit

- ⇒ 1/2, 3/4, or 1HP, 208-240V, Single Phase
- ⇒ 1450 RPM Motor
- ⇒ Oil Cooled
- ⇒ Continuous Duty Rated Motor
- ⇒ Two Long Life Bearings
- ⇒ Thermal Overload Protection
- ⇒ Fully Unitized Heavy Duty Carbon Ceramic Mechanical Seal
- ⇒ Series 300 Austenitic Stainless Housing with Engineering Grade Thermoplastic Top

Float

- ⇒ U.V. Resistant High Density Thermoplastic
- ⇒ Expanded Polystyrene (EPS) Filled
- ⇒ Single Piece Float
- ⇒ Series 300 Stainless Steel Hardware
- ⇒ Protective Coated Stainless Steel Bottom Screen; 84 Vertical Screening Bars w/ Gaps Tapered from 222mm to 48mm on Bottom Screen

Power Cable

- ⇒ 10m or 1m Stub Cord
- ⇒ Rubber Jacket, 3 Conductor Power Cord with Earth Conductor
- ⇒ Potted Quick Disconnect and Stainless Steel Strain Relief Standard on all Stub Cords
- ⇒ Flex Sleeve Cord Protection

Optional Lights

- ⇒ 2 or 3 Machined Bronze Fixtures
- ⇒ 12V, 75W MR-16 Bulbs
- ⇒ Remote Transformer
- ⇒ Thermal Overload Protection
- ⇒ Triple Sealed

Fountain Components

- ⇒ UV Resistant Engineered Thermoplastic Propeller
- ⇒ UV Resistant Thermoplastic Draft Tube and Fountain Disc with Series 300 Stainless Steel Hardware

Kasco 2400EVFX, 3400EVFX, & 4400EVFX Specifications

Model #	HP	Cord Length	Watts	Voltage/Phase/Hz	Running Amps	Lock Rotor Amps	Sugg. Pond Size*	Min. Depth of Operation	Shipping Weight	Number of Boxes
2400EVFX000	1/2	Stub	484	220/1/50	2.2	5.3	1,300m ²	38cm	20 kg	2
2400EVFX010	1/2	10m	484	220/1/50	2.2	5.3	1,300m ²	38cm	22.5 kg	2
3400EVFX000	3/4	Stub	792	220/1/50	3.6	12.8	2,000m ²	45cm	24 kg	2
3400EVFX010	3/4	10m	792	220/1/50	3.6	12.8	2,000m ²	45cm	26.3 kg	2
4400EVFX000	1	Stub	1,298	220/1/50	5.9	19.6	3,000m ²	49cm	25 kg	2
4400EVFX010	1	10m	1,298	220/1/50	5.9	19.6	3,000m ²	49cm	28 kg	2

* Pond Size is determined by multiplying length x width of the pond. The actual shape, depth, and oxygen demand should be considered when selecting a unit size.

Kasco Optional Lighting Package Specifications

Model #	Cord Length	Number of Fixtures	Lamp Volt/Phase/Hz (SELV)	Wattage Per Fixture	Total Wattage	Lens Position	Shipping Weight	Number of Boxes
LE275000	Stub	2	12/1/50	75	150	Above Water	7.7 kg	1
LE375000	Stub	3	12/1/50	75	225	Above Water	9 kg	1

Light Kits include a built in, remote Low Voltage Isolating Transformer. Light kits are connected to 220V mains that should have RCD protection.

LE275 is not recommended on 1HP fountains.

Use Warnings

- Max Water Temp of 35°C
- For Use in Non-Explosive Areas Only
- Use to Pump Water Only
 - Non-Flammable
 - Non-Toxic
 - Non-Corrosive (salt water is acceptable)
- Do Not Run the Unit Dry
- Discontinue use and remove when water is below 0°C.
- RCD (residual current device) or GFCI (ground fault circuit interrupter) protected circuit required



The Optional Lighting Package easily mounts to the float and can be purchased and added at any time.

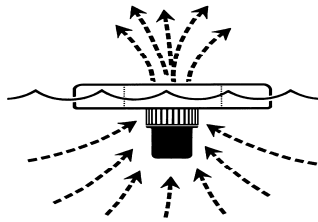

During unit operation, water is circulated from 360° around the unit as well as from below. Top intake for shallow water operation.

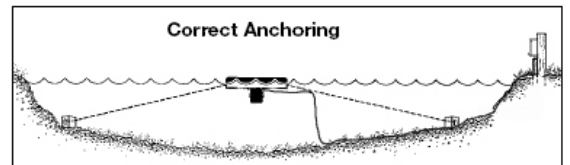

Assembly and Installation of Kasco equipment is quick and easy. Each unit includes an Owners Manual with specific steps to assemble, install, and operate the equipment properly.

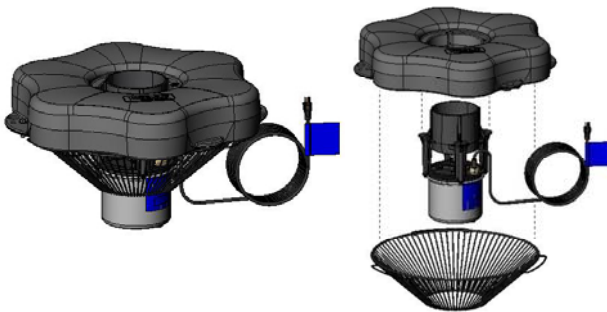

The motor unit attaches to the float using stainless steel hardware for a secure assembly. The single section, U.V. resistant, high density thermoplastic, EPS filled float allows for excellent durability with an attractive shape and low visibility. The rigid bottom screen help protect the unit from debris and reduce the likelihood of clogging.

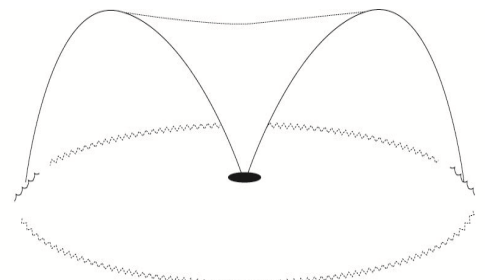

Kasco Marine, Inc.
800 Deere Rd.
Prescott, WI 54021

Ph: 1-715-262-4488 * Fax: 1-715-262-4487
www.KascoMarine.com * www.GotAlgae.com
Sales@KascoMarine.com



Rev. 2/2/11