



Making a Splash!

Owners Manual

Submersible Light Kits

LR275 & LR375



Contents

Important Safety.	pg2
General Instructions.	pg2
PARTS INCLUDED.	pg3
LR275 Light Kit Assembly Instructions.	pg4
LR375 Light Kit Assembly Instructions.	pg4
Instructions On Adapter Kit For 6 Lights.	pg5
Maintenance Recommendations.	pg6
Warranty Policy.	pg7
Troubleshooting Tips.	pg8
Replacement Parts Diagram.	pg9
Customer Repair Form.	pg10
Registration Information.	pg11



UL 676 8th Ed. 2004

Kasco Marine, Inc.
800 Deere Rd.
Prescott, WI 54021
PH (715) 262-4488
FAX (715) 262-4487
www.kascomarine.com

Rev. 11/10/08

THANKS

We at Kasco Marine, Inc. would like to both thank and congratulate you on your purchase of the Submersible Light Kit. We appreciate you choosing Kasco and for your purchase. Your decision to purchase Kasco's Submersible Light Kit will not disappoint you. Some NEW features to Kasco's Submersible Light Kits are Thermal Protection from overheating and added seal protection of the light fixtures and cord. The Submersible Light Kit will illuminate your fountain for a beautiful display day and night. We thank you for choosing Kasco for your fountain and aeration needs and want you to be completely satisfied with your purchase.

Important Safety

Please read and follow these extremely important safety and handling instructions for your Kasco equipment. Following these instructions will help ensure your safety and the quality performance of your equipment.

- All serviceable parts of the light kit are low voltage (12Vac). The power connection for the light kit is 120Vac and MUST be plugged into a GFCI receptacle.
- Under NO circumstances should anyone enter the water with the electrical equipment plugged in and/or in operation. All Kasco equipment is designed and built to UL and CSA standards for safety in water and all fountain models include control panels with GFI protection. However, it is NEVER recommended to enter the water with the equipment in operation.
- Caution should be used when dealing with any electrical and/or moving equipment.
- NEVER run the unit out of water. It will damage the seals and create a dangerous situation for the operator.

- Extreme caution should be used around water, especially cold water, such as in Spring, Fall, and Winter, which poses a hazard in and of itself.
- NEVER lift or drag the fountain or light kit by the power cords. If you need to pull the unit to the side of the pond, use the anchoring ropes.
- Do not use waders in deep ponds/lakes or ponds/lakes with drop-offs, drastic slopes, or soft bottom material.
- Do not use boats that tip easily for fountain installation (ex. Canoes)
- The fountain is supplied with an internal grounding conductor and a grounding-type attachment plug. To reduce the risk of electrical shock, be certain that the fountain is plugged into the C-25 Control Box (120V) or C-85 Control Panel (240/208V) supplied by Kasco and that the C-25 is plugged or wired into a properly grounded, grounding type receptacle or the C-85 is wired properly to the electrical service.
- The C-85 control panel must be installed a minimum of 5 feet (3m in Canada) from the body of water unless separated from the body of water by a fence, wall, or other permanent barrier that will make the unit inaccessible to persons in the water.

General Instructions

INSPECT THE SHIPMENT

Immediately inspect your Kasco Submersible Light Kit shipment for any visible damages. Also cross reference the Parts Included sheet with the parts supplied to check for shortages. Shortages should be reported immediately to your Kasco Marine distributor or representative and damages reported to your carrier and Kasco Marine.

CAUTION

WARNING: Under NO circumstances should anyone enter the water with the unit in operation. Always operate the unit in the water and keep people and objects clear of the propeller. Do not lift the unit by the electrical cord. Always use extreme caution around electrical equipment and water situations.

ASSEMBLY & INSTALLATION

Please see the proper Assembly and Installation Instructions enclosed in this manual. Each is specific for your model and size of Fountain and Light Kit. Note: Use the nylon tie provided to help keep the power cord for the lights free of the propeller by tying the cord to the float opposite the fountain power cord or to the mooring rope opposite the fountain power cord.

WARRANTY

Kasco Fountains and Light Kits are the result of over 35 years of design and engineering. Kasco products are built to withstand the toughest conditions. Kasco Marine backs each Fountain and Submersible Light Kit with a 3 Year Warranty. This warranty covers any and all manufacturers defects within 3 years from the date of purchase (See Warranty, Warranty Claim, & Return Policy on pages 9 & 10).

Kasco Fountains are lightweight, energy efficient, and easy to install and operate. We strive to produce products that exceed customer expectations. We hope you enjoy your Kasco Fountain.

PARTS INCLUDED

LR275

- A. Light Kit with cord (1)
- B. 75-watt, 12-volt, MR-16 Halogen Bulbs, installed in fixtures (2)
- C. 1/4" x 1" Stainless Steel Bolts (2)
- D. 1/4" Stainless Steel Flat Washer (2)
- E. 1/4" Stainless Steel Lock Washer (2)
- F. 1/4" Stainless Steel Nut (2)
- G. Nylon Cable Tie
- H. Optional Colored Bulbs

Note: Extra hardware may be included.

L375

- A. Light Kit with cord (1)
- B. 75-watt, 12-volt, MR-16 Halogen Bulbs, installed in fixtures (3)
- C. 1/4" x 3/4" Stainless Steel Bolts (3)
- D. 1/4" Stainless Steel Flat Washer (3)
- E. 1/4" Stainless Steel Lock Washer (3)
- F. 1/4" Stainless Steel Nut (3)
- G. Nylon Cable Tie
- H. Optional Colored Bulbs

Note: Extra hardware may be included.

TOOLS & SUPPLIES NEEDED

- A. 7/16" Wrench
- B. Flat Head Screw Driver
- C. Diagonal Pliers or Cutter for Nylon Zip Ties

LR275 Light Kit Assembly Instructions

Instructions for mounting lights on Model 2400VFX, 3400VFX, 3400HVFX, 3400JF, & 3400HJF Aerating Fountains

STEP ONE:

Cut Nylon Zip Ties that hold the fixture cords in a coil. Insert the 1/4" x 1" bolt into the light bracket so the flats of the hex head bolt are between the support ribs of the bracket as shown in Figure 1. Align the light bracket to the float tab by placing the bolt through the light mounting hole in the underside of the float tab as shown in Figure 2.



Fig. 1

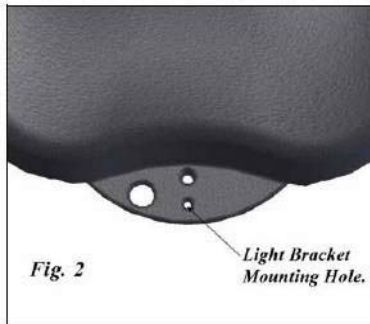

Fig. 2

Light Bracket Mounting Hole.

STEP TWO:

Install the 1/4" Flat Washer, 1/4" Lock Washer and 1/4" Nut against the underside of the float tab as shown in Figure 3. Tighten the nut until snug using the 7/16" Wrench.

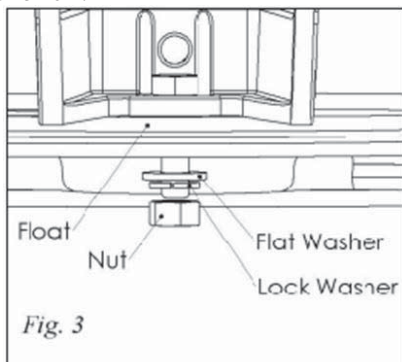

Fig. 3

STEP THREE:

Adjust the angle of the light as desired and tighten the two brass screws on the sides of the fixture until snug. Do not over tighten. It is best to have all two or three fixtures at the same angle.

STEP FOUR:

Repeat steps 1 through 3 for the remaining fixture. The completely assembled light fixture is pictured in Figure 4. Note the orientation of the lights.



Figure 4
2 light install



Figure 5
3 light install

STEP FIVE:

Upon installation of the assembled unit, connect your lighting package to the C-25 or C-85 Control Panel. The LR275 has a 120V, NEMA 5-15P Plug that should be plugged into the GFCI protected outlet labeled "Lights" in the appropriate control panel.

STEP SIX:

Using the nylon cable tie provided, tie the light kit power cord to the float or rope opposite the fountain power cord. This will keep the cord from being damaged by the fountain and balance the unit properly.

STEP SEVEN:

Each light fixture and cord entrance must be submerged at least 1" in order for lights to operate properly.

LR375 Light Kit Assembly Instructions

Instructions for mounting lights on Model 4400VFX, 4400HVFX, 8400VFX, 8400JF, 3.1JF & 5.1JF Aerating Fountains

NOTE: For 4400VFX & 4400HVFX follow Assembly Instructions on previous page for LR275, but repeat with third light fixture. See Figure 5 on previous page for correct orientation. Also use LR275 instructions If you purchased the LR375 for use on 2400 & 3400 models.

STEP ONE:

For ease of assembly, make sure the Aerating Fountain is completely assembled. Place the assembly upright and if needed, use blocks to support the float.

STEP TWO:

Cut Nylon Zip Ties that hold the fixture cords in a coil. Insert the 1/4" x 3/4" bolt into the light bracket so the flats of the hex head bolt are between the support ribs of the bracket as shown in Figure 1. Align the light bracket to the lower float bracket by placing the bolt through the light mounting hole in the lower float bracket as shown in Figure 2.

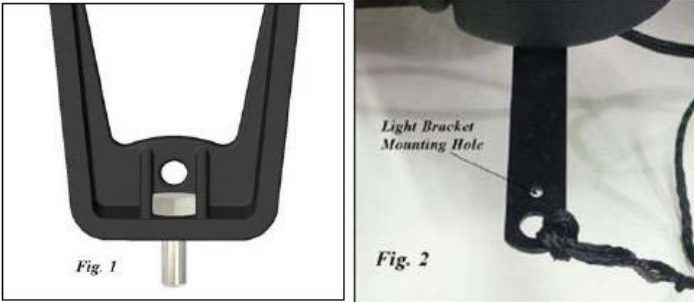

STEP THREE:

Install the 1/4" Flat Washer, 1/4" Lock Washer and 1/4" Nut against the lower float bracket as shown in Figure 3. Tighten the nut until snug using the 7/16" Wrench.

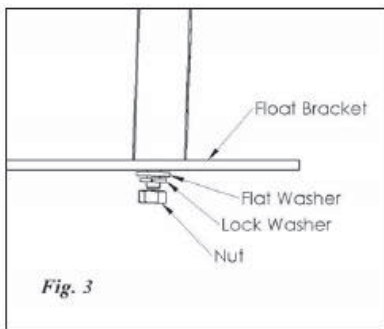

STEP FOUR:

Adjust the angle of the light as desired and tighten the two brass screws on the sides of the fixture until snug. Do not over tighten. It is best to have all three fixtures at the same angle.

STEP FIVE:

Repeat steps 2 through 4 for the remaining two fixtures. The completely assemble light fixture is pictured in Figure 4.



STEP SIX:

Upon installation of the assembled unit, connect your lighting package to the C-85 Control Panel. The LR375 has a 120V, NEMA 5-15P Plug that should be plugged into the GFCI protected outlet labeled "Lights" in the C-85 control panel.

STEP SEVEN:

Using the nylon cable tie provided, tie the light kit power cord to a float bracket or rope opposite the fountain power cord. This will keep the cord from being damaged by the fountain and balance the unit properly.

STEP EIGHT:

Each light fixture and cord entrance must be submerged at least 1" in order for lights to operate properly.

Instructions On Adapter Kit For 6 Lights

Instructions for attaching 2 LR375 light kits on Model 8400JF, 3.1JF, & 5.1JF Aerating Fountains

Adapter kit (Part# 840322) includes:

1. Lower float brackets (Qty 6)
2. 3/8" washers (Qty 3)
3. Round Spacers (Qty 6)
4. 1/4" x 2" Stainless Steel Bolts (Qty 6)

Note: Part #3 and Part #4 are only used with the 8400JF & 3.1JF assembly

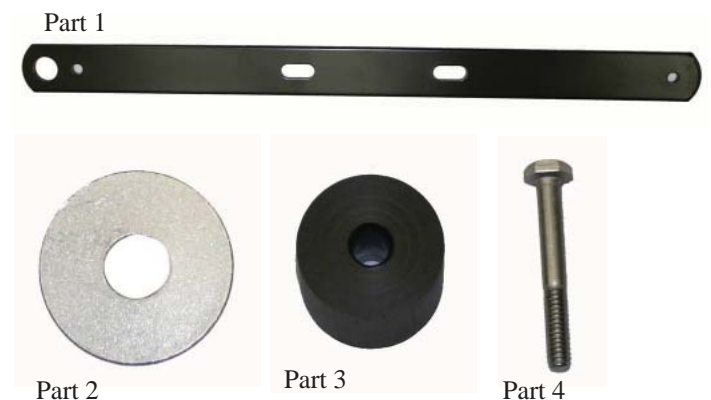

1. Turn the unit upside down. Loosen and remove the 3/8" nuts on the three 9" bolts that are closest to the motor unit. Place 2 Lower Float Brackets(Part #1) and one 3/8" washer(Part #2) on each of the 9" bolts over the bottom screen clips and replace the 3/8" nut.



2. Arrange the brackets into the position shown, then tighten down the nuts. Once the brackets are secure, turn the unit back into its upright position.



3. For the 5.1JF, follow the instructions on the previous page for installation of the lights onto the lower float brackets. For the 8400JF & 3.1JF follow the instructions on the previous page except use the 1/4" x 2" bolts (part #4) that came with the adapter kit instead of the bolts that came with the light kit, and use the round spacers (part #3) between the light fixture bracket and the lower float bracket. You do not need to use the round spacers for the 5.1JF assembly.



For 8400JF & 3.1JF
Use 2" bolts & Round Spacers

Maintenance Recommendations

** Under No Circumstances should anyone enter the water while a fountain is operating. **

** Please keep the original box for maintenance shipping. **

The following maintenance procedures can be utilized to ensure many years of quality performance from your Kasco Fountain and Light Kit and reduce the need for more costly repair work.

PROPER INSTALLATION: Proper installation of Kasco equipment will include a power source with ground fault interruption. For Fountain models, the C-25 control (120V) or C-75 (240/208V) included with the unit have built-in ground fault interruption that is sufficient. Ground fault interrupters are a safety feature that can also alert you to electrical leaks in the equipment. If you have repeat, consistent trips on your ground fault, the equipment should be disconnected and removed from the water. The power cord should be inspected for damage and you should call Kasco Marine at 715-262-4488 for further instructions or email Kasco at service@kascomarine.com.

OBSERVATION: Operating equipment should be observed on a regular basis (daily, if possible) for any reduction or variation in performance. If a change in performance is observed, the equipment should be disconnected from power and inspected for any material that may have clogged the system or wrapped around the shaft of the motor, especially plastic bags and fishing line. Even though Kasco Aerators and Fountains are among the most clog-resistant on the market, it is impossible to protect against all items that can clog equipment and still maintain a flow of water. These materials can be very damaging to the equipment under continued operation and must be removed as soon as possible. **ALWAYS UNPLUG THE UNIT BEFORE ATTEMPTING TO REMOVE CLOGS.**

WINTER STORAGE: In regions where there is significant freezing in the wintertime, the fountain and light kit should be removed from the water to protect them from the expansion pressure of the ice. In many areas, fountains will keep some amount of ice open through the winter. However, when the water is thrust into the air, it is exposed to the colder air temperatures longer and can actually make ice thicker on the pond/lake. Storage over winter is best in a location that is out of the sun and cool, but above 32OF. It is not necessary to store Kasco motors upside down. All internal seals are fully lubricated while stored in an upright position.

Warranty Policy

CLEANING: Fountains and light kits should be removed from the water at least once per year (at the end of the season in cold climates) to clean the exterior of the system, especially the stainless steel motor housing (can) and light fixtures. The motor housing and brass light fixtures is the surface that dissipates heat into the water and any algae, calcium, etc. build-up will become an insulator that blocks heat transfer. In warmer regions it is recommended that the motor is removed and cleaned at least two to three times per year depending on conditions. In most cases a power washer will be sufficient if the unit and algae are still wet. Also make sure the lens of the light fixtures is clean to ensure the brightest light possible.

SEAL AND OIL REPLACEMENT: This is a sealed motor assembly and seals will wear out over time (similar to break pads on a car). Replacement of the seals and a change of oil after three to five years may add longevity to the operation of the motor, saving you the cost of more expensive repairs. In warmer climates where the fountain runs most or all of the year, it is a good idea to replace seals more regularly than you would need to in colder climates where the unit is removed from the water for several months.

ZINC ANODE: A Sacrificial Zinc Anode is supplied on the shaft of all 1/2HP to 2HP Fountains for protection of the equipment from corrosion and electrolysis. The zinc anode should be updated (replaced) if reduced to half the original size or if white in color. Corrosion from electrolysis is more commonly associated with saltwater or brackish water, but as a matter of precaution, it is important to periodically check the zinc anode in all installations (at least every two to three months).

Repair services should be performed by Kasco Marine or a Kasco trained Authorized Repair Center. Any alterations or changes made to Kasco units by an unauthorized source will void the warranty. This includes tampering with the unit, power cord, and/or control box. Please contact Kasco Marine, Inc. at 715-262-4488 for your nearest Authorized Repair Center.

3 Year Limited Warranty: Kasco® Marine, Inc. warrants this Light Kit to be free from defects in material or workmanship under normal use and service. The Kasco Marine, Inc. obligation under this warranty is limited to replacing or repairing free of charge any defective part within three (3) years from the date of shipment. Customer shall pay shipping charges for returning the unit to Kasco.

THIS WARRANTY IS IN LIEU OF ANY OTHER WARRANTIES, EXPRESSED OR IMPLIED, AND ANY OTHER OBLIGATION OR LIABILITY WHATEVER ON THE PART OF KASCO MARINE, INC. AND IN NO EVENT SHALL KASCO MARINE, INC. BE LIABLE FOR ANY SPECIAL OR CONSEQUENTIAL DAMAGES.

Warranty is void if:

The Light Kit is not maintained properly according to the Maintenance Recommendations supplied in this Owners Manual.

The Light Kit is returned for repair without the power cord or if the unit, control box, or power cord are altered in any way from original shipment. Cuts in the power cord are not covered under warranty.

The Light Kit is damaged by unauthorized tampering.

Warranty Claim Procedure:

The warranty coverage can be established by the date of purchase receipt or by calling Kasco Marine, Inc. Please call Kasco Marine at 715-262-4488 prior to shipping to receive a Return Authorization Number and/or Repair Form, then ship to:

Kasco Marine, Inc.
800 Deere Rd.
Prescott, WI 54021
Attn: Repairs

You can also email Kasco at service@kascomarine.com.

Note: Only complete Light Kit assemblies will be accepted for warranty repair. The power cord and all other components must be returned with the Light Kit as originally assembled. Any missing parts will be replaced at the customer's expense and, if determined to have caused the failure, could void the entire warranty. Some parts are essential for structural support during shipping and others,

Troubleshooting Tips

such as the power cord, are essential to properly diagnose potential causes of failure. It is not necessary to return the control box or float with the motor assembly.

Please include the Repair Form received from Kasco Marine or your local distributor with the shipment. If no Repair Form is available, include your name and physical address for return delivery of the repaired Light Kit and a daytime phone number and/or e-mail address for correspondence regarding the warranty claim.

Any expedited shipping method for the return of the unit is at the customer's expense. Kasco Marine will return units repaired under warranty at our expense via ground freight

Other Repairs:

Most failed equipment can be repaired at substantially lower costs than replacement with new. Please ship according to the instructions in the previous section. Again, it is best to call ahead for a Return Authorization Number and/or Repair Form so we know the repair is coming.

Kasco Marine offers free estimates on repairs at the request of the customer. The request for estimate should be included in the letter that accompanies the returned Light Kit and must include a daytime phone number and/or e-mail address. Estimate options are as follows:

We will contact the customer with a total after the Light Kit has been evaluated, but before the work is performed. We will repair the Light Kit only if repair costs are under a stated dollar amount. Example: "Please repair if total is under \$150.00 before shipping charges."

All estimates that are rejected for repair will be destroyed unless otherwise directed by the customer. If the customer would like the Light Kit returned, it will be restored as closely as possible to the condition in which it was received and shipped at the customer's expense for shipping and handling charges.

Billing:

All non-warranty repairs will be returned to the customer and billed C.O.D. unless otherwise directed. Kasco Marine also accepts Visa and MasterCard credit card payments. Kasco Marine will call for credit card information upon completion of the repair at the customer's request.

All other warranty and repair inquiries should be directed to Kasco Marine, Inc. at 715-262-4488 or returns@kascomarine.com.

Below are some helpful troubleshooting tips. If a problem occurs, please double check the assembly and installation instructions as well as the instructions for the proper control panel and fountain model. More troubleshooting tips can be found at www.kascomarine.com (under the technical tab).

"I have installed my lights and wired them properly, but they will not turn on."

Kasco Control Boxes are equipped with Photoelectric Eyes that measure the amount of ambient light. When the Photo Eye measures darkness, it will allow power to flow to the transformer, and thus to the light kit. It must be dark for the lights to operate. You can cover the Photo Eye to test the lights, but it takes a few minutes to register the darkness.

"It is dark, but my lights will not turn on."

This can indicate a few possible problems. The bulbs could be burnt out or not fully inserted into the receptacles. The GFCI outlet in the C-25 or C85 control panel may also be tripped. Use the manual reset button on the breaker to reset the GFCI.

"When my lights try to turn on, the 20 Amp breaker in my C-85 trips."

This is a common symptom of a missing or improper neutral wire coming into the C-85 Control Panel. The C-85 requires two hots, a ground, and a neutral wire for proper operation. Without a proper neutral, the breaker will trip when the lights try to turn on. Make sure there is a neutral wire and that it is in proper working order.

"My lights have been working for sometime, but don't seem to be as bright as when first installed."

If this symptom occurs, unplug the fountain and lights. Pull the fountain and lights into shore and inspect the lenses on the lights. Over time, there could be some algae growth or hard water deposits on the lenses which will block some light. Clean the lenses with a soft brush and the light should be bright again.

"My lights seem to turn off an on by themselves (not by the timer)".

The lights have built in thermal overload protection to protect against overheating. When the light overheats, it turns off and then turns back on when it has cooled. If this occurs, make sure at least 1" of the lights are under the water.

LR275 / LR375 REPLACEMENT PARTS LIST

ITEM NO.	PART NO.	DESCRIPTION	Replacement Parts/Qty.
1	344070	HOUSING, LIGHT BODY	1
2	375125	LAMP, MR-16, 75 WATT	1
3	344100	WINDOW, LIGHT	1
4	344090	O RING	3
5	322450	MOUNTING BRACKET, MOLDED	1
6	321005	SCREW, 1/4-20 X 1/2, BRASS	2
7	344072	CAP, LIGHT HOUSING	1
8	321010	FLAT WASHER, BRASS, 1/4"	2
9	348315	RETAINING RING	1

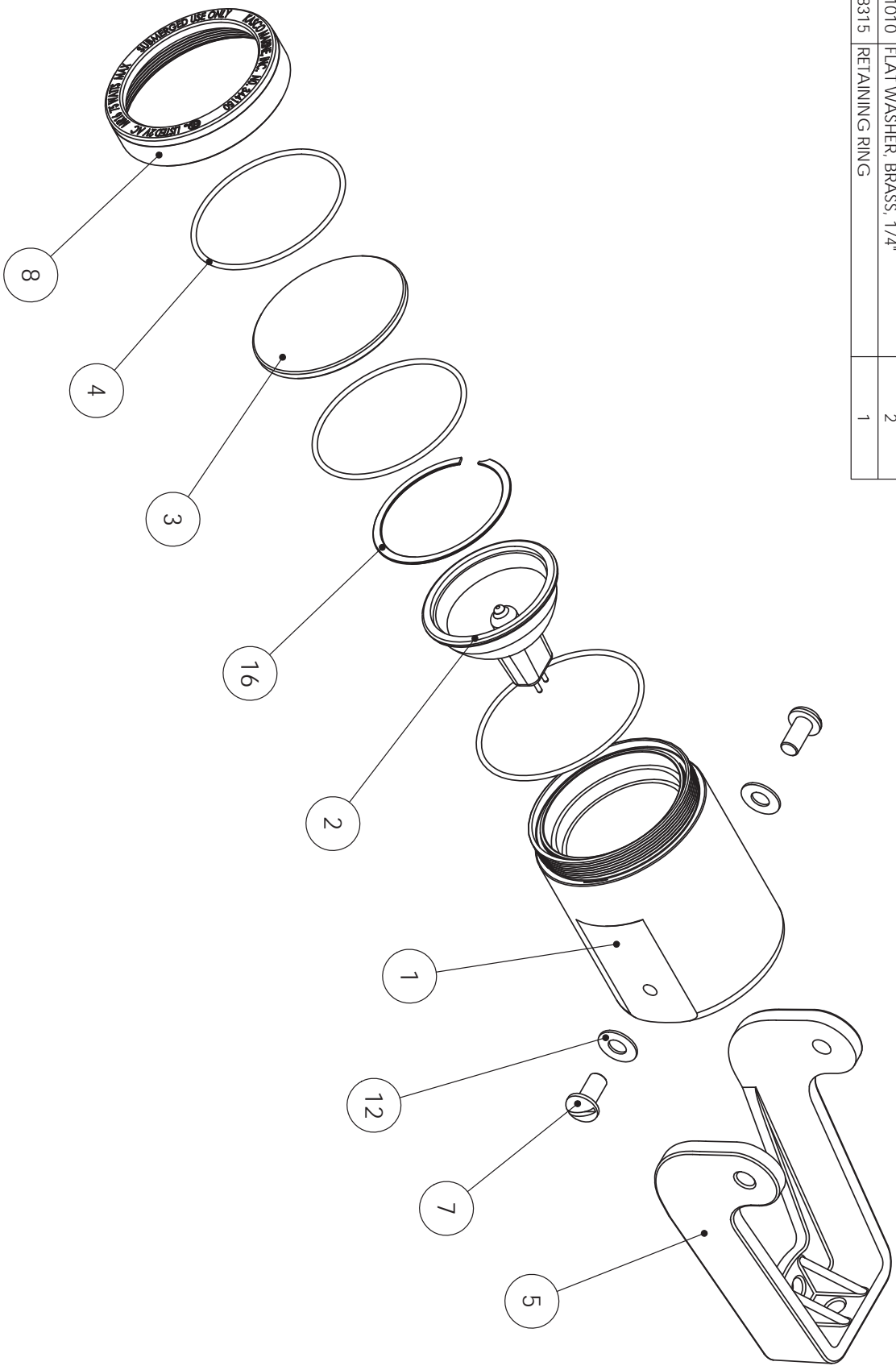



800 Deere Rd.
 Prescott, WI 54021
 Phone: 715-262-4488 - Fax: 715-262-4487
 www.KascoMarine.com Sales@KascoMarine.com

Customer Repair Form

*** Important Reminders ***

- All repairs sent in **MUST** be accompanied by a copy of this completed sheet!
- Address your Repair to Kasco Marine, Attn: Repairs (or to your Authorized Repair Center).
- Shipping to Kasco or an Authorized Repair Center is paid for by the customer.
- You must include the power cord with each unit sent in for repair to be considered for warranty repair!
- Do not ship the control box with the unit for repair, unless otherwise instructed.

Today's Date: _____

Customer Information

Name: _____

Phone Number: _____

Address: _____

Alternate Number: _____

City: _____

Email Address: _____

State: _____

Zip Code: _____

Unit Information:

Model # (Ex. LR375): _____

Date Purchased: _____

Purchased From: _____

Earliest Date of Problem: _____

Description of Problem:

Comments:

Registration Information

Fill in the information below and keep for your records.

Model # (Ex. LR375) _____

Purchase Date: _____

Purchased From: _____

Registration Date: _____



Kasco Marine, Inc.
800 Deere Rd.
Prescott, WI 54021

Phone (715) 262-4488 * Fax (715) 262-4487

www.kascomarine.com * sales@kascomarine.com * service@kascomarine.com