



WaterGlow™

LL1020 Submersible Landscape Light Owners Manual

*Thermal Overload
Protection, Gasket, &
Potting Eliminate Leaks.*

Contents

Important Safety Instructionspg2
General Owner's Instructionspg2
Warranty Policypg3
Maintenance Recommendationspg5
Installation Instructionspg6
Troubleshooting Tipspg7
Replacement Partspg8
Customer Repair Formpg9



3020379
UL 676 8th Ed. 2004

Kasco Marine, Inc.
800 Deere Rd.
Prescott, WI 54021
PH (715) 262-4488
FAX (715) 262-4487

www.kascomarine.com • sales@kacomarine.com

Rev 11/10/08

THANKS!

We at Kasco Marine, Inc. would like to both thank and congratulate you on your purchase of the Low Voltage Lighting. We appreciate you choosing Kasco and for your purchase. Your decision to purchase Kasco's Low Voltage Light will not disappoint you. Some NEW features to Kasco's Low Voltage Lights are Thermal Protection from overheating and added seal protection of the light fixtures and cord. We thank you for choosing Kasco for your low voltage lighting needs and want you to be completely satisfied with your purchase.

Important Safety Instructions

Please read and follow these extremely important safety and handling instructions for your Kasco lighting. Following these instructions will help ensure your safety and the quality performance of your equipment.

- **Always disconnect power from light before service or relamping.**
- Kasco Low Voltage Lighting must be used with a 12V AC Transformer with wattage capacity greater than the sum of all light wattages on the circuit. (Ex. Three 75W bulbs on the same circuit would require a transformer of at least 225W or greater.)
- Caution should be used when dealing with any electrical equipment.
- **NEVER** lift or drag the light by the power cord.
- This Light is designed for submerged use (see installation instructions). The internal temperature protection will disable the light if it is not submerged and greater than 20 watt bulb is used.

General Owner's Instructions

INSPECT THE SHIPMENT

Immediately inspect your Kasco Low Voltage Lighting shipment for any visible damages. Also cross reference the Parts Included sheet with the parts supplied to check for shortages. Shortages should be reported immediately to your Kasco Marine distributor or representative and damages reported to your carrier and Kasco Marine.

CAUTION

Up to a 75W bulb can be used if the light fixture is submerged in water at least 1" to allow for proper cooling. Failure to do so could damage the light. Do not lift the light by the electrical cord. Always use extreme caution around electrical equipment and water situations.

ASSEMBLY & INSTALLATION

Please see the proper Assembly and Installation Instructions enclosed in this manual. Each is specific for your model Light Kit.

USE AND OPERATION

Kasco Low Voltage Lighting must be used with the proper size 12V AC Transformer. The wattage of this transformer must be greater than the sum wattage of all the bulbs used on that circuit. (Ex. Three 75W bulbs on the same circuit would require a transformer of at least 225W or greater capacity.) The wires on the Low Voltage Lighting must be wired into the transformer per instructions included with the transformer. The White and Black wires on the Low Voltage Lighting are the HOT wires. The Green wire is the GROUND wire.

This light is designed for submerged use. The internal temperature protection will disable the light if it is not submerged and a greater than

20 watt bulb is used.

Kasco's Low Voltage Lighting also has added sealing technology for longer life and less water leakage on the fixture and the cord.

Kasco Low Voltage Lighting is lightweight, energy efficient, and easy to install and operate. We strive to produce products that exceed customer expectations. We hope you enjoy your Kasco Low Voltage Lighting.

Warranty Policy

3 Year Limited Warranty: Kasco® Marine, Inc. warrants this Light Kit to be free from defects in material or workmanship under normal use and service. The Kasco Marine, Inc. obligation under this warranty is limited to replacing or repairing free of charge any defective part within three (3) years from the date of shipment. Customer shall pay shipping charges for returning the unit to Kasco or an Authorized Repair Center.

THIS WARRANTY IS IN LIEU OF ANY OTHER WARRANTIES, EXPRESSED OR IMPLIED, AND ANY OTHER OBLIGATION OR LIABILITY WHATEVER ON THE PART OF KASCO MARINE, INC. AND IN NO EVENT SHALL KASCO MARINE, INC. BE LIABLE FOR ANY SPECIAL OR CONSEQUENTIAL DAMAGES.

Warranty is void if:

The Low Voltage Lighting is not maintained properly according to the Maintenance Recommendations supplied in this Owners Manual.

The Low Voltage Lighting is returned for repair without the power cord or if the power

cord is altered in any way from original shipment. Cuts in the power cord are not covered under warranty.

The Low Voltage Lighting is damaged by unauthorized tampering.

Warranty Claim Procedure:

Check the Date Code stamped on the light fixture to determine the month and year of manufacture. The stamp is on the fixture just below the mounting bracket.

Sample Date Code

0506

The first two digits represent the month of manufacture. (Ex. "05" for May)

The third and fourth digits represent the year. (Ex. "06 for 2006)

Once the warranty coverage has been established, the Low Voltage Lighting may be sent to any Kasco Authorized Repair Center for evaluation and repair. Please call Kasco Marine at 715-262-4488 prior to shipping to receive a Return Authorization Number and/or Repair Form, then ship to:

Kasco Marine, Inc.
800 Deere Rd.
Prescott, WI 54021
Attn: Repairs

Or call Kasco Marine at 715-262-4488 to locate your nearest Authorized Repair Center. You can also email Kasco at service@kasco-marine.com.

Note: Only complete Low Voltage Lighting assemblies will be accepted for warranty repair. The power cord and all other components must be returned with the Low Voltage Lighting as originally assembled. Any missing parts will be replaced at the customer's expense and, if determined to have caused the failure, could void the entire warranty. Some parts are essential for structural support during shipping and others, such as the power cord, are essential to properly diagnose potential causes of failure. It is not necessary to return the control box or float with the motor assembly.

Please include the Repair Form received from Kasco Marine or your local distributor with the shipment. If no Repair Form is available, include your name and physical address for return delivery of the repaired Low Voltage Lighting and a daytime phone number and/or e-mail address for correspondence regarding the warranty claim.

Any expedited shipping method for the return of the unit is at the customer's expense. Kasco Marine will return units repaired under warranty at our expense via ground freight within the continental United States.

Other Repairs:

Most failed equipment can be repaired at substantially lower costs than replacement with new. Please ship according to the instructions in the previous section. Again, it is best to send the unit in with the Customer Repair Form near the end of this manual.

Kasco Marine offers estimates on repairs at the request of the customer. The request for estimate should be included in the form that accompanies the returned Light Kit and must

include a daytime phone number and/or e-mail address. Estimate options are as follows:

We will contact the customer with a total after the Low Voltage Lighting has been evaluated, but before the work is performed. We will repair the Low Voltage Lighting only if repair costs are under a stated dollar amount. Example: "Please repair if total is under \$150.00 before shipping charges."

All estimates that are rejected for repair will be destroyed unless otherwise directed by the customer. If the customer would like the Low Voltage Lighting returned, it will be restored as closely as possible to the condition in which it was received and shipped at the customer's expense for shipping and handling charges.

Billing:

All non-warranty repairs will be returned to the customer and billed C.O.D. unless otherwise directed. Kasco Marine also accepts Visa and MasterCard credit card payments. Kasco Marine will call for credit card information upon completion of the repair at the customer's request.

All other warranty and repair inquiries should be directed to Kasco Marine, Inc. at 715-262-4488 or returns@kascomarine.com.

Maintenance Recommendations

** Please keep the original box for maintenance shipping. **

The following maintenance procedures can be utilized to ensure many years of quality performance from your Kasco Low Voltage Lighting and reduce the need for more costly repair work.

PROPER INSTALLATION: Kasco Low Voltage Lighting must be used with a properly sized 12V AC Transformer. The wattage of the transformer must be greater than the total sum wattage of the lights used on that circuit. The Low Voltage Lighting wires must be wired into the transformer per instructions included with the transformer. The White and Black wires are the HOT wires, Green is the GROUND wire. Each light fixture must be submerged at least 1” below the water surface for proper cooling during operation.

OBSERVATION: Operating equipment should be observed on a regular basis (daily, if possible) for any reduction or variation in performance. If a change in performance is observed, the light should be disconnected from power and inspected for any debris buildup. Any buildup should be removed with a brush or pressure washer. Make sure the lens of the light is clean to ensure the brightest light.

WINTER STORAGE: In regions where there is significant freezing in the wintertime, the Low Voltage Lighting should be removed from the water to protect them from the expansion pressure of the ice.

CLEANING: Low Voltage Lighting should be removed from the water at least once per year (at the end of the season in cold climates)

to clean the exterior of the system, especially fixtures. The bronze light fixtures is the surface that dissipates heat into the water and any algae, calcium, etc. build-up will become an insulator that blocks heat transfer. In warmer regions it is recommended that the Low Voltage Lighting is removed and cleaned at least two to three times per year depending on conditions. In most cases a power washer will be sufficient if the unit and algae are still wet. Also make sure the lens of the light fixtures is clean to ensure the brightest light possible.

Repair services should be performed by Kasco Marine or a Kasco trained Authorized Repair Center. Any alterations or changes made to Kasco units by an unauthorized source will void the warranty. This includes tampering with the unit, power cord, and/or control box. Please contact Kasco Marine, Inc. at 715-262-4488 for your nearest Authorized Repair Center.

Installation Instructions

PARTS INCLUDED

1. LL1020
2. Light fixture with 12 Volt 75W MR-16 Halogen bulb and 20' cord (1)
3. Brass Screws (2)
4. Brass Flat Washers (2)
5. Retaining Ring (1)
6. Mounting Bracket set (1)

TOOLS & SUPPLIES NEEDED

1. Flat Head Screw Driver
2. Properly sized remote transformer listed for use with submersible luminaries.

STEP ONE:

Mount the fixtures in the desired locations. Up to a 75W bulb (Included) can be used if the light fixture is submerged in water at least 1" to allow for proper cooling. Failure to do so could damage the light. If the included base is being used, rocks, sand, etc. can be placed on the base to keep the light in the desired location. A 1/2" PVC pipe can be added to the base to raise the height of the light or the base can be removed and the PVC pipe can be installed into the ground.

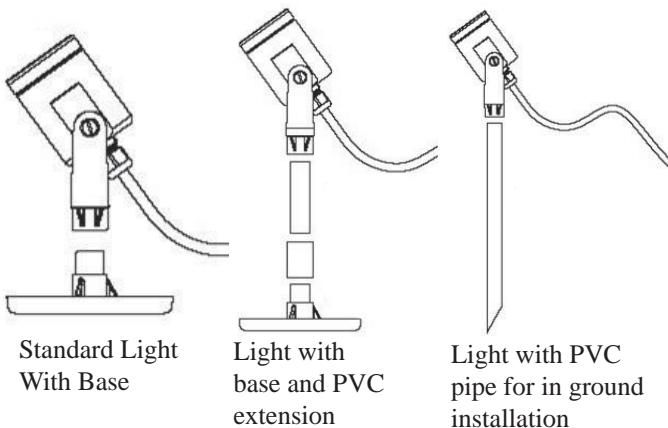

STEP TWO:

Adjust the angle of the light fixture as desired and tighten the two brass screws on either side of the fixture to hold that angle.

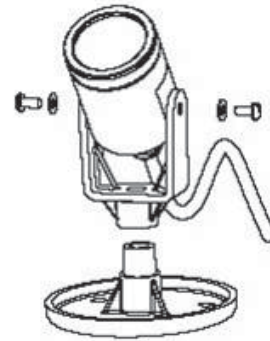

STEP THREE:

Wire the cord from the Low Voltage Lighting into the properly sized 12V AC Transformer. The transformer must have a wattage capacity of at least the total sum wattage of all the lights on the circuit. (Ex. Three 75W bulbs would require a transformer of at least 225W or greater.) The Black and White wires on the Low Voltage Lighting are the HOT wires. They should be wired into the transformer per the instructions included with the transformer. The Green wire is the GROUNDING wire for the light fixture. The Green wire must be connected to a ground per your local electrical code. If in doubt, contact a qualified electrician.

STEP FOUR:

If the transformer has a timer included with it, set the timer per the instructions included with the transformer for the desired ON and OFF times.

STEP FIVE:

Plug the transformer into your 120V power outlet and enjoy your NEW Kasco Low Voltage Lighting.

LAMPING/RELAMPING

1. Turn off power to light.
2. Unscrew the cap and remove the lens.
Install lamp by pushing lamp pins into socket.
3. Seat lamp into fixture and hold in place with included stainless steel retaining ring.
4. Make sure the O rings are correctly seated and reinstall the lens and cap onto the fixture.

Troubleshooting Tips

Below are some helpful troubleshooting tips. If a problem occurs, please double check the assembly and installation instructions as well as the instructions for the transformer used. More troubleshooting tips can be found at www.kascomarine.com (Under the Technical tab)

“My light has been working for sometime, but don’t seem to be as bright as when first installed.”

If this symptom occurs, unplug the light. Inspect the lenses on the lights. Over time, there could be some algae growth or hard water deposits on the lenses which will block some light. Clean the lenses with a soft brush and the light should be bright again.

“My lights seem to turn off an on by themselves (not by the timer)”.

The lights have built in thermal overload protection to protect against overheating. When the light overheats, it turns off and then turns back on when it has cooled. If this occurs, make sure at least 1” of the lights are under the water and make sure you are using the proper bulb size.

LL1020 REPLACEMENT PARTS

ITEM NO.	PART NUMBER	DESCRIPTION	QTY
1	344070	HOUSING, LIGHT BODY	1
2	344100	WINDOW, LIGHT	1
3	344090	O RING	3
4	344072	CAP, LIGHT HOUSING	1
5	348202	YOKE, BRACKET, LANDSCAPE LIGHT	1
6	348210	BRACKET, BASE	1
7	321005	SCREW, 1/4-20 X 1/2, BRASS	2
8	321010	FLAT WASHER, BRASS, 1/4"	2
9	348315	RETAINING RING	1
10a	375125	CLEAR LAMP, MR-16 75 WATT.	1
10b	350125	YELLOW LAMP, MR-16 50 WATT.	1
10c	350140	RED LAMP, MR-16 50 WATT.	1
10d	350155	GREEN LAMP, MR-16 50 WATT.	1
10e	350170	BLUE LAMP, MR-16 50 WATT.	1

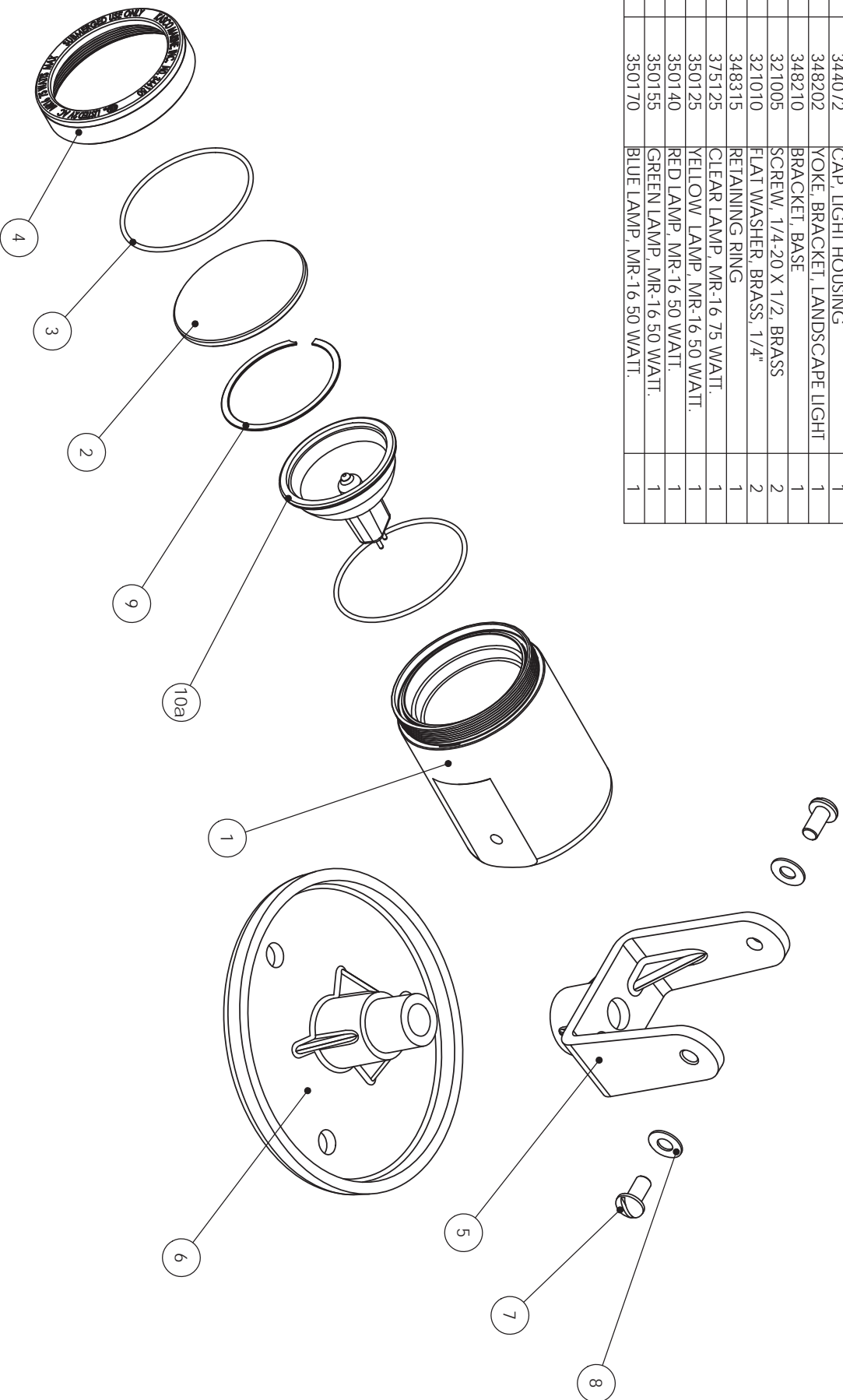



800 Deere Rd.
 Prescott, WI 54021
 Phone: 715-262-4488 - Fax: 715-262-4487
 www.KascoMarine.com Sales@KascoMarine.com

Customer Repair Form

*** Important Reminders ***

- All repairs sent in **MUST** be accompanied by a copy of this completed sheet!
- Address your Repair to Kasco Marine, Attn: Repairs (or to your Authorized Repair Center).
- Shipping to Kasco or an Authorized Repair Center is paid for by the customer.
- You must include the power cord with each unit sent in for repair to be considered for warranty repair!

Today's Date: _____

Customer Information

Name: _____

Phone Number: _____

Address: _____

Alternate Number: _____

City: _____

Email Address: _____

State: _____

Zip Code: _____

Unit Information:

Model # (Ex. LL1020): _____

Serial #: _____

Date Purchased: _____

Purchased From: _____

Earliest Date of Problem: _____

Description of Problem:

Comments:



Kasco Marine, Inc.
800 Deere Rd.
Prescott, WI 54021

Phone (715) 262-4488 * Fax (715) 262-4487

www.kascomarine.com * sales@kascomarine.com * service@kascomarine.com